







SC-2000 *CONDOR*® TRAILER-ONLY CHOCK USER INSTRUCTION MANUAL

STOP! WARNING: READ THIS FIRST!

First Read and Understand the Instruction manual and product labels for important safety, set-up and troubleshooting information. If you have problems setting up or using the *CONDOR*® Trailer-Only Chock, contact customer service @ 1-815-754-7418 or contact us via e-mail @ www.condor-lift.com. *CONDOR*® Trailer-Only Chock is not intended for use by children.

Assembly Instructions: Remove all parts from shipping box. Check the parts below to make sure you have all the parts needed to assemble your *CONDOR*® Trailer-Only Chock before beginning. In the unlikely event that you find a part damaged or missing, please call customer service @ #815-754-7418.

Parts	Key	Qty.	Description
	A	1	<i>CONDOR</i> ® Trailer-Only Chock (SC-2000) w/ (3) x 1/2" x 8.5" Front Stop / Cradle Pin w/ Hitch Pin Clip (Z119)
	B	2	Trailer-Only Mounting Strips (S-PB41-C)
	C	4	5/16"-18 x 1/2" Thumbscrew (S-148488)
	D	4	3/8"-16 x 2.5" Hex Tap Bolt (S-13817)
	E	8	3/8" x 1.5" Fender Washer (S-33220)
	F	4	3/8" -16 Nylock Nut (S-37024)

Assembly Illustrations:

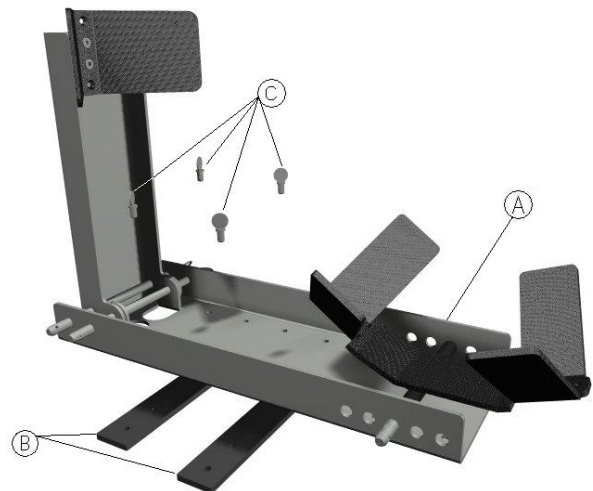
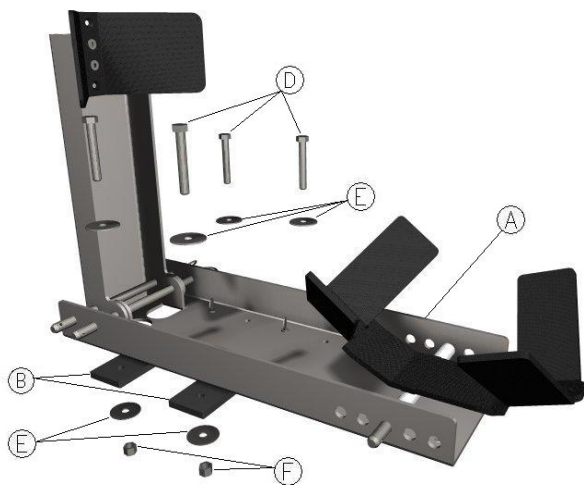

User Instructions:

Determine a mounting location for the SC-2000 with the mounting strips (B) still attached to the unit. Holding the unit in place, drill (1) 3/8" hole through trailer floor using the mounting strip hole as a guide. Use the hardware provided (D, E, F) to hold the unit in place while making sure that the unit is positioned square with the trailer. Drill the second 3/8" hole through the other mounting strip hole in the opposite corner from the first hole. Use the hardware provided (D, E, F) to secure the unit before drilling the last two holes. Use the remaining hardware provided (D, E, F) to completely secure the unit to the trailer floor. When the SC-2000 is not in use, it can be easily removed by simply detaching the (4) thumbscrews (C) and lifting it from the mounting strips, leaving the strips attached to the floor. To re-attach, line up the holes in the base of the unit with the threaded holes in the mounting strips. Secure the unit into place again using the (4) thumbscrews. (**REFER TO CAUTION PARAGRAPH BELOW**) Confirm that the cradle is set in the optimized position setting (See **RECOMMENDED CRADLE SETTINGS**) for the entering tire and wheel. Adjustment of cradle is crucial for optimum retention. Optimum retention is achieved by trying different settings. (**REFER TO CAUTION PARAGRAPH BELOW**): If the optimum vertical support is achieved, the motorcycle will hold itself upright. If optimum retention is not achieved try different cradle settings. (**REFER TO CAUTION PARAGRAPH BELOW**). As an extra precaution, one may use an optional bungee cord to strap the cradled wheel to the front stop (Optional bungee cord purchased separately). Always strap bungee through the wheel and around the front stop below the upper front stop flange. For more information on usage, adjustments, and installation, refer to www.condor-lift.com.

RECOMMENDED CRADLE SETTINGS:

The **CONDOR**® Trailer-Only Chock is designed so that for every tire/wheel size within the ranges specified a minimum of 2 cradle settings is suitable.

****The optimum cradle setting for a specific tire would be, the setting that allows the cradle to tilt as far forward as possible without making contact with the unit itself.****

The 2nd optimum setting would be the setting forward from the optimum setting away from the entry direction. If less retention is desired at any time due to too much retention or sticking, the cradle may be moved away from the entry direction one notch.

RACING APPLICATIONS:

For bikes with GP or low durometer front tires compounds, use the 5th cradle setting from the entry directions.

CAUTION:

Always make sure that all fasteners are tight and all pins are in place prior to use. Understand the limitations of this product and do not exceed these limitations. Always make sure that the unit's cradle settings are optimum for the tire size of the motorcycle before use. For bikes with very low fenders and/or cowlings, a custom cradle may be purchased fitted to specific tire sizes, so as not to make contact. For standard sport bike front wheel combinations, the 1, 2, 3, front settings may be suitable. If instructions are not clear, additional information is available at www.condor-lift.com or call 1-800-461-1344. Technical Components Development & Design is not responsible for any damage incurred by exceeding this product's limitations in structure and/or functionality.

One Year Limited Warranty:

This **CONDOR**® Trailer-Only Chock product warranty extends to the original consumer purchaser of the product. All illustrations and specifications contained in this manual are based on the latest product information available at the time of printing. Technical Components Development & Design, Inc. reserves the right to make changes at any time, without notice, in color, materials, equipment, options, specifications and models. Models may be shown with optional equipment. Further information may be obtained by contacting Technical Components Development & Design, Inc. @ 815-754-7418.

Warranty Duration:

This product is warranted to the original consumer purchase for a period of one (1) year from original purchase date.

What is not covered:

Our warranty for your product will not cover abnormal wear of parts, damage resulting from negligent use or misuse of the product, use contrary to operating instructions, or disassembly, repair or alteration by any person other than an authorized service station. We shall not be liable for any incidental or consequential damages for breach of by express or implied warranty on your product.

Return Policy:

15 day return policy applies. Merchandise may be returned within 15 days of purchase. Merchandise must be unused and in its original packaging. Customer will call TC Development for a Return Authorization number. Customer pays for freight return. Credit is given upon inspection of returned goods. A 15% re-stocking fee applies to all returned merchandise. If the product was originally shipped with a free shipping promotion, the cost of shipping will be deducted from the dollar amount of the return in addition to the restocking fee.

How your state's law may apply:

Some states do not allow limitations on how long any implied warranty lasts or the exclusion or limitation of incidental or consequential damages. So the above limitation may not apply to you. This warranty gives you specific legal rights, and you may also have other rights, which may vary from state to state.

Thank you for purchasing the **CONDOR**® Trailer-Only Chock.

Patent Number: RE 42,735

CONDOR® is a registered trademark of Technical Components Development & Design, Inc.

The **CONDOR**® Trailer-Only Chock is US Patented & International Patent Pending.

Technical Components Development & Design, Inc.

CONDOR® Products

210 W. Stephenie Drive

Cortland, IL 60112

Phone: (815) 754-7418

Fax: (815) 754-7419

Web Site: www.condor-lift.com